

Final Project Info

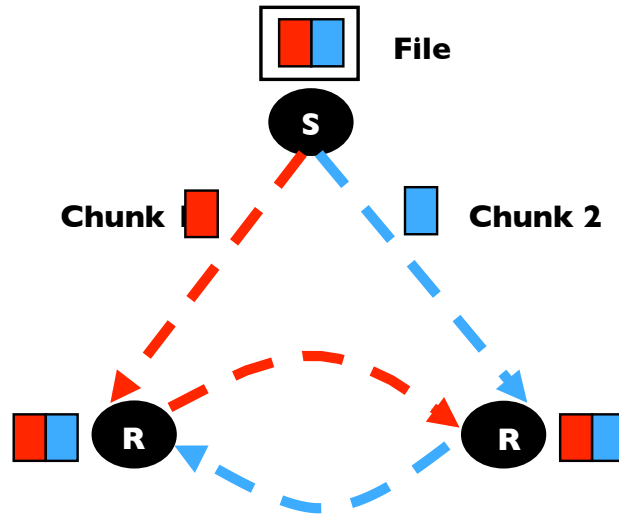

Not Recommended



Replication

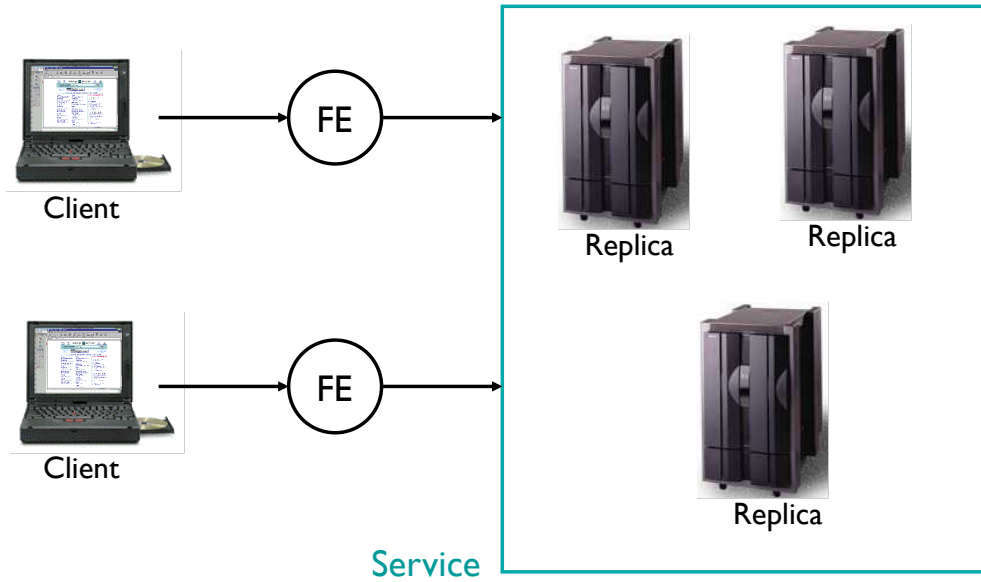

Passive Replication

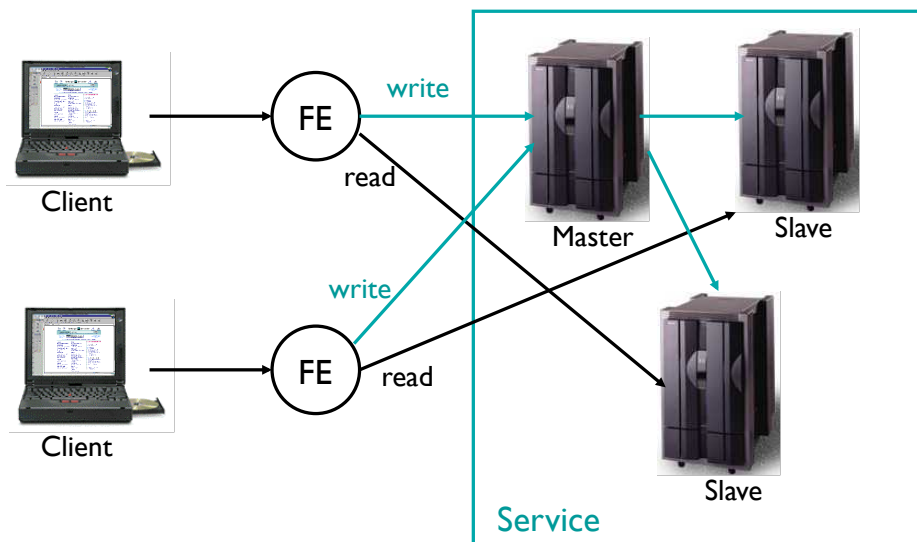

Active Replication

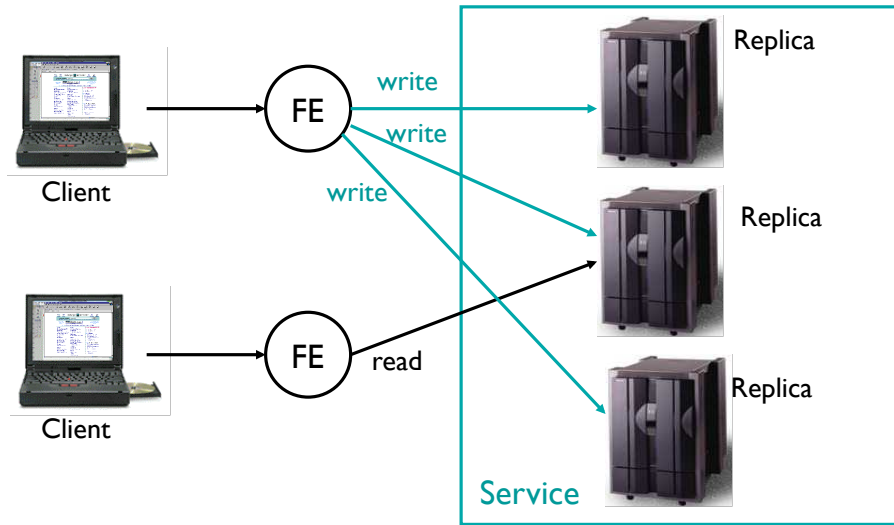

Gossip Architecture

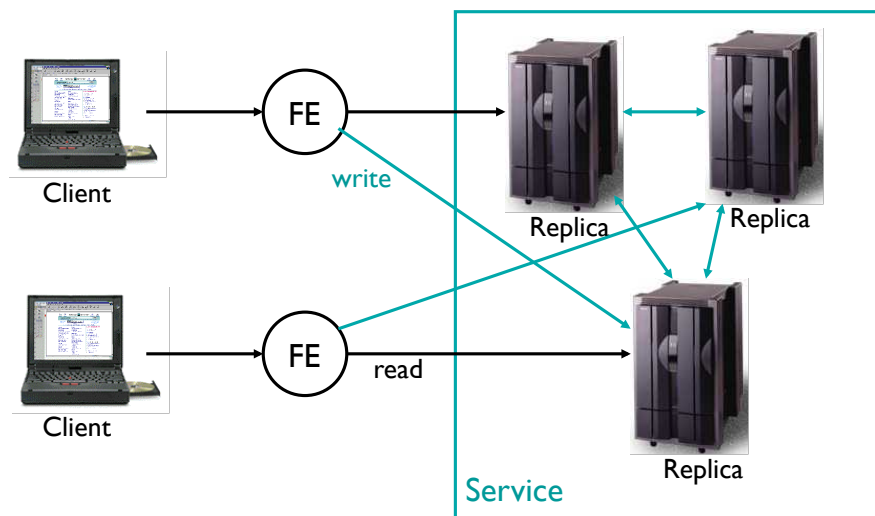

Fault Tolerance

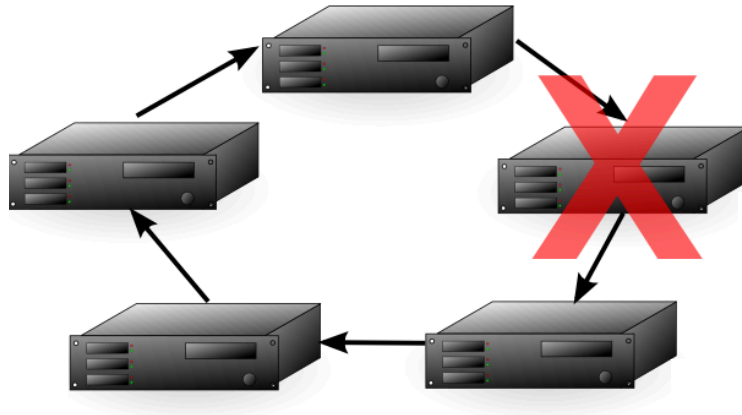

Redundancy

